

Pyroterra Lighttoys  
presents

# FT2 CHIP INSTALLATION GUIDE

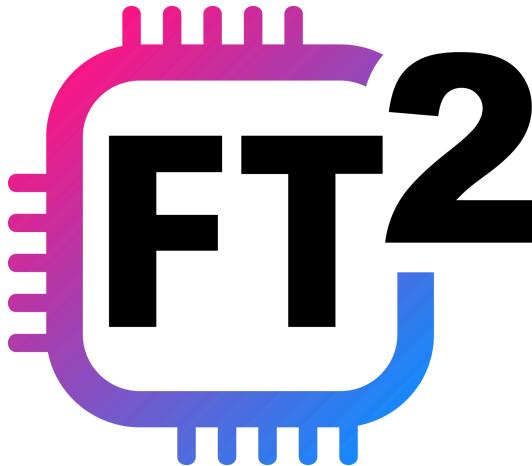

**v2.5**

**Note: installation of the FT2 chip must be performed only by individuals with knowledge of electronic circuits and soldering skills.**

# Introduction

FT2 chip brings the power of digital pixel LED strips into your custom LED decorations, costumes and props. The FT2 chip offers full compatibility with FT remotes, other Lighttoys props and the LtComposer programming software. Thanks to its cutting-edge features and flexible installation options, FT2 chip opens new creative possibilities for the discerning artist.

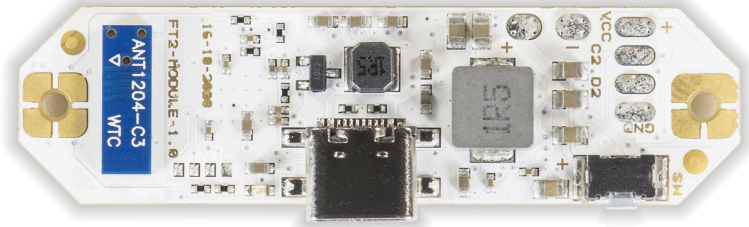

## Chip specification

**dimensions:** 58 x 16 x 6 mm, **weight:** 4.9 g  
**supported LED strips:** 5V digital LED strips (APA102, WS2812, WS2813, WS2815 variants)  
**supply voltage:** 3.3-5.0V, **stabilized output voltage:** 4.0V  
**max. output power:** 40W / 10A (~180 LEDs at max. brightness)  
**max. number of LEDs:** 600  
**operational temperature:** -10°C to +90°C  
**USB-C fast charging:** yes 1.5A

## Modes of operation

The FT2 chip can be installed & operated in 2 different ways:

- A) *Battery powered using the voltage converter (recommended)*
- B) - D) *Using external power (advanced)*

## ***A) Battery powered using the voltage converter***

This is the recommended use of the FT2 chip in most scenarios. The FT2 chip includes a DC-DC boost voltage converter that manages stable output voltage (~3.9V), even as the battery voltage drops under high load and discharge, providing a stable and reliable functionality of the attached LED strip(s).

### **Digital LED strip attachment**

The FT2 chip is fully compatible with the 4-wire APA102 LED strip and the 3-wire WS2812 LED strip (including their variants & clones). We recommend the APA102 based on its superior performance.

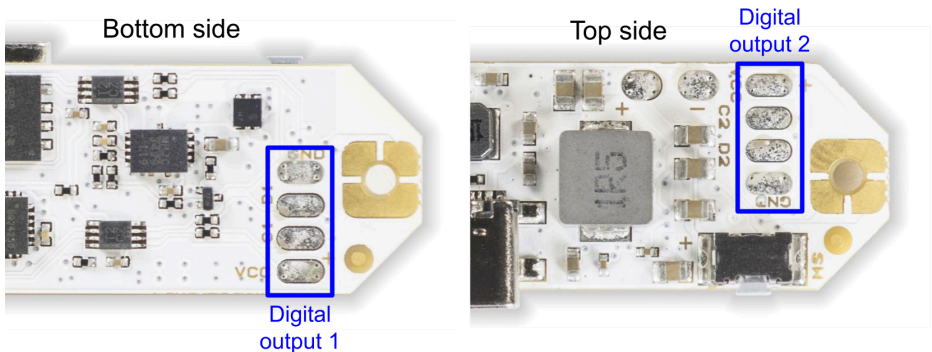

The FT2 chip has 2 sets of digital outputs, one from each side of the board. By default, the digital output #2 mirrors the functionality of the digital output #1 and come preconfigured as follows:

**LED strip type:** APA102 (4-wire interface)  
**Number of controlled LEDs:** 60 pixels

This configuration can be later changed in the LtComposer software.

## 4 wire digital LED strip

If you have decided to use the 4-wire LED strip type with separate clock and data signals (e.g. APA102, APA107, SK9822), connect its digital input pads to the FT2 chip as follows:

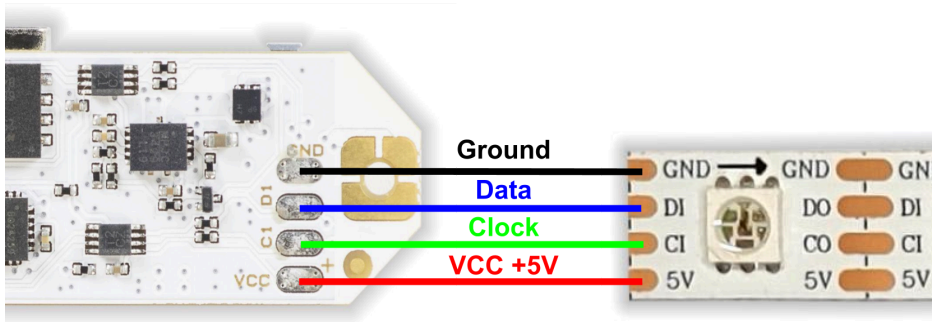

## 3 wire digital LED strip

If you have decided to use the 3-wire LED strip type with one data signal (e.g. WS2812, SK6812), connect its digital input pads to the FT2 chip as follows:

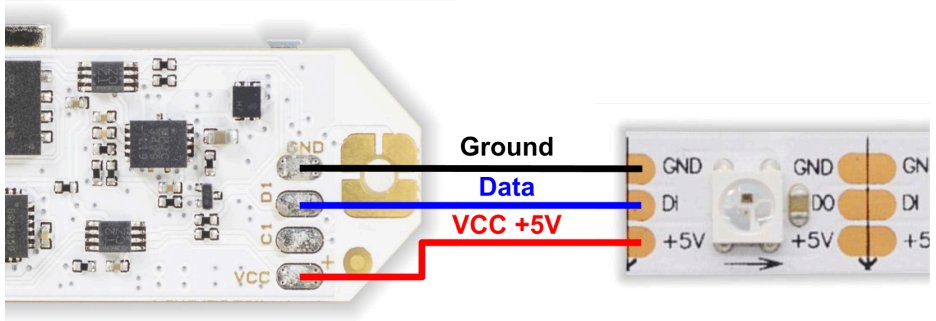

## 3+1 wire digital LED strip

If you have decided to use the 3+1 wire LED strip type with extra backup (redundant) data line (e.g. WS2813, SK6822), connect its digital input pads to the FT2 chip as follows:

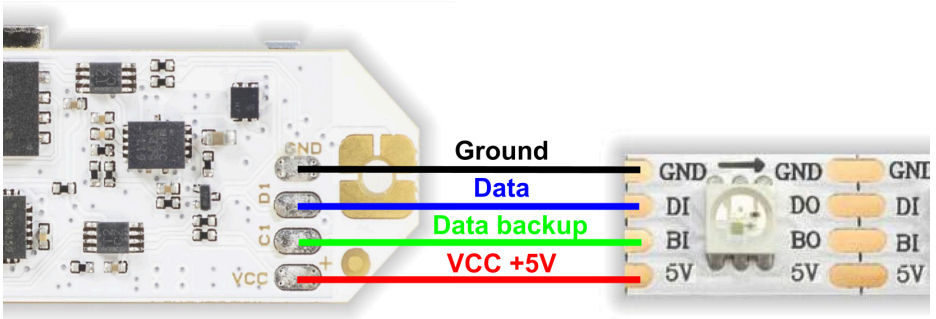

## Battery connection

The FT2 chip is designed to be powered from a single 3.7V Li-ion battery, or several Li-ion batteries connected in parallel (to increase the total discharge current & capacity).

When opting for the parallel configuration, make sure the batteries are sourced from the exact same manufacturer, type and batch.

Protection circuit on each battery is highly advised.

**Safety tip:** solder the "+" cable first, so there is no risk of short circuit with the nearby capacitor.

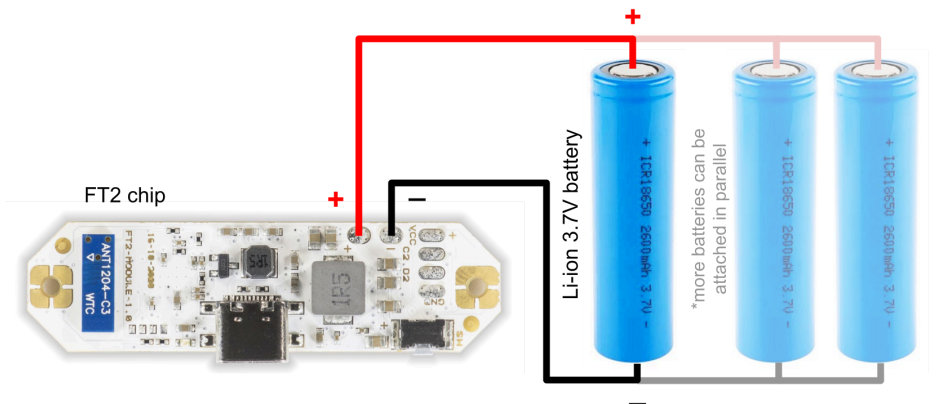

**Caution:** supplying voltage higher than 5V or reversing the polarity of the battery will damage the FT2 chip!

When selecting a suitable battery for your LED project, you must follow the approximate formulas for battery capacity & discharge current:

**Battery capacity (mAh)** = no. of LEDs x 15 (3000mAh is enough)

**Discharge current (A)** = no. of LEDs x 0.05 (12A is enough)

**A low resistance of the power lines is critical. Always use thick (>0.5mm<sup>2</sup>/20AWG) & short (<30cm) cables between the FT2 chip and its battery. The voltage drop should be less than 0.2V at full power. If you need to use any connectors, use only the high current types like XT60, Deans or EC3.**

## Powering up

Now that you have connected the digital LED strip and the battery, it is time to power up the FT2 chip for the first time!

First, connect an USB charger cable to the USB-C connector. If the attached battery is not yet fully charged, the charging LED should start pulsing in **blue color**, indicating a charging process.

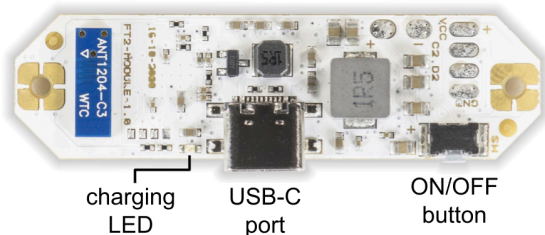

Now, press the ON/OFF button for **1 second** to power up the chip. If you have the APA102 LED strip type connected, you should already see the power up indication (light ramping up) on its LEDs.

If you have the WS2812 or WS2813 LED strip type connected, there will be no light output yet, the FT2 chip must be configured in the LtComposer software first.

# FT2 chip configuration

Attach the FT2 chip with an USB cable to your computer, make sure it is turned on and start the LtComposer software (version 3.5+). The FT2 chip should be detected as connected in the status bar:



Connected devices: 1 

Click on the **Devices** menu at the top, then select the FT2 chip and click on the **Device config** button.

A new window will open, where you can give your FT2 chip its default name, set the pixel length (resolution), LED strip type and which digital outputs will be active. The **Brightness** setting is automatically limited based on the number of LEDs to prevent chip overload.

Click **Apply to device** to save the new configuration into the FT2 chip and turn it off / on. Your FT2 chip should be now ready to use!

## Troubleshooting & FAQ

Having troubles? Before contacting Lighttoys customer support, please read the following FAQs first:

**Problem: the chip seems dead when the ON/OFF button is pressed and the blue charging LED is not shining when attached to the USB charger.**

- 1) Check your battery cables for no short-circuit or reversed polarity.
- 2) Check that the battery is not faulty and powerful enough, producing a stable voltage in the range 3.3-4.2V (under load).

**Problem: the digital LED strip is not shining at all, or showing random / white color.**

- 1) Check the connection of DATA / CLOCK wires.
- 2) Check that the correct digital output (1 or 2) is used.
- 3) Make sure the LED strip type (APA102 vs. WS2812) matches the configuration set in LtComposer.
- 4) Replace / cut the LED strip, the first LED can often be broken.

**Problem: when I power on the chip and display solid color on the LED strip at full brightness, the chip immediately turns off (with or without red blinking).**

- 1) The battery is empty, attach a 5V USB charger to the FT2 chip USB-C port and leave it charge to the full, until the blue charging LED stops pulsing.
- 2) The battery is undersized and not supplying enough power when under stress. Use a more powerful battery or several batteries connected in parallel.
- 3) The power cables from the battery are not thick or short enough, or improper connectors are used.
- 4) Brightness setting in LtComposer is set too high (overloading the chip), please reduce it.

**Problem: when I display white color at maximum brightness on the LED strip, the color changes to dim yellow / orange after some time.**

- 1) The thermal protection of the voltage converter got activated and reduced the output voltage. Improve the cooling of the chip or reduce the max brightness in LtComposer.

## **FT2 chip mounting**

The FT2 chip can be installed into your target device using the two 2mm mounting holes and M2 sized PCB standoffs (not included):



If you are using metal standoffs, make sure to put M2 nylon washers from both sides of the chip hole, to prevent a short-circuit of the neighbor pads.

The FT2 chip can get very hot, especially when used at the maximum rated output. Never put the FT2 chip into a plastic shrink wrap or airtight confined space. In some cases, ventilation holes might be necessary.

Top side

Bottom side

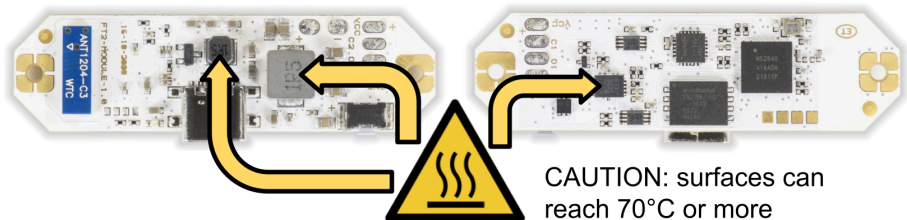

Note: FT2 chip contains thermal protection - if the temperature reaches 100°C, the chip will turn off to protect itself.

## Using the external interface

In some projects, you might want to use your own ON/OFF button and USB connector that are externally mounted and connected to the chip with hookup wires. In such cases, use the auxiliary connection pads around the holes:

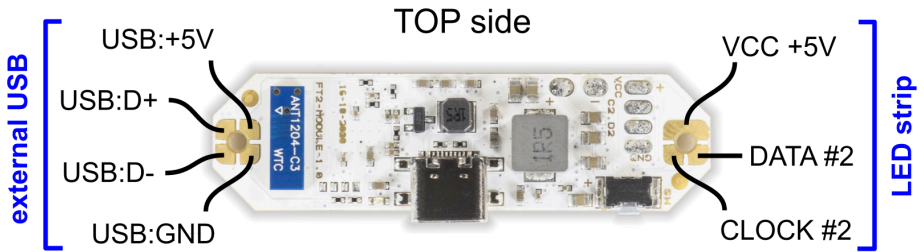

Connect your external ON/OFF button switch between the **BAT+** and **SW** pads. Use the push button (tactile) type of switch, not a rocker type of switch:

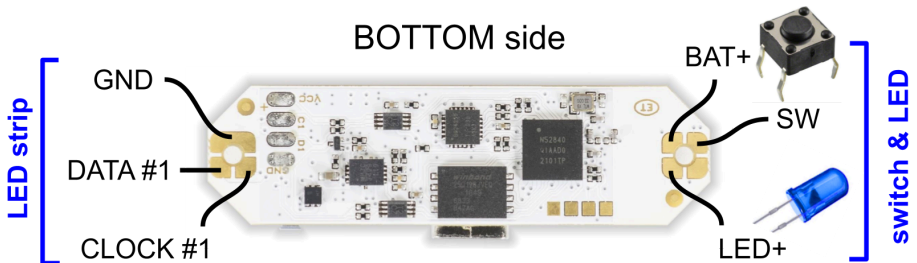

Connect a LED diode (forward voltage: 1.7-3.3V) between the **LED+** and any **GND** pad to get an external battery charging indication.

When opting for an external USB-C connector board, you must connect the CC1 and CC2 pins to the ground using two 5.1 Kiloohm ( $k\Omega$ ) resistors, otherwise the fast charging capability and USB-C data connection won't work (only USB Type A).

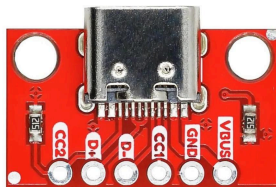

See the proper connection diagram below:

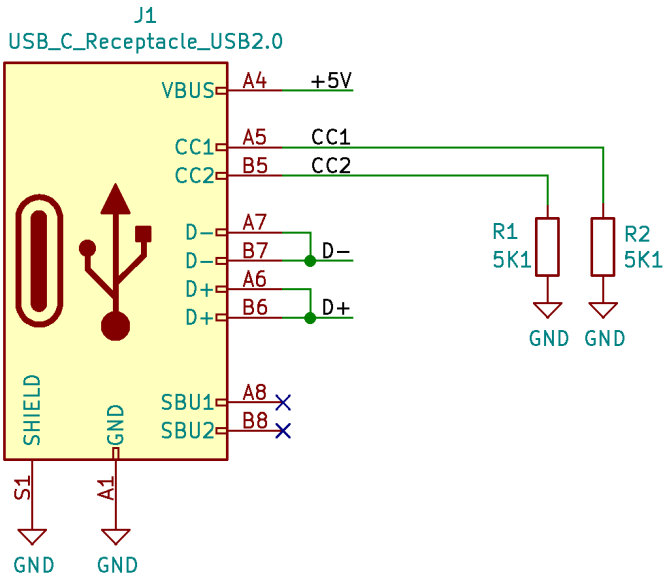

## Power distribution to the LED strips

To get an optimal performance from your FT2 chip application, it is important to ensure steady voltage across your LED strips.

Digital LED strips rated for +5V voltage (like APA102 and WS2812) are susceptible to serious voltage losses over longer strip lengths, leading to poor color fidelity, or no functionality at all. A typical situation with a longer digital LED strip is shown below:

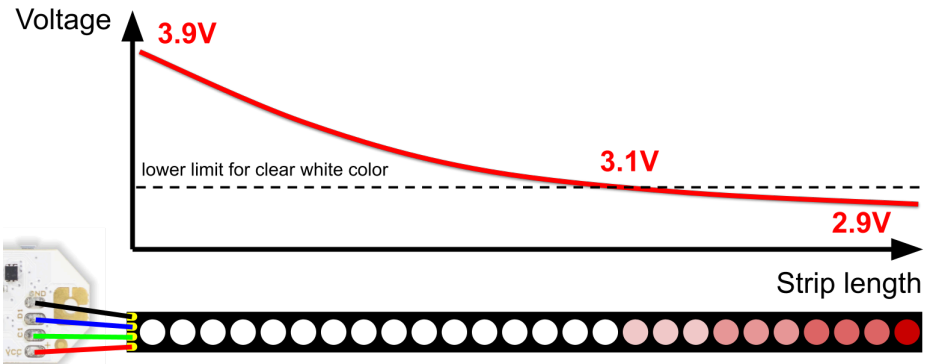

This problem starts to show with LED digital strips as short as 100-150 pixels. To combat the inevitable voltage drop, run parallel power cables of sufficient thickness ( $>0.5\text{mm}^2/22\text{AWG}$ ) from the **VCC** and **GND** pads of the FT2 chip and connect them to the digital LED strip at several spots along its total run length:

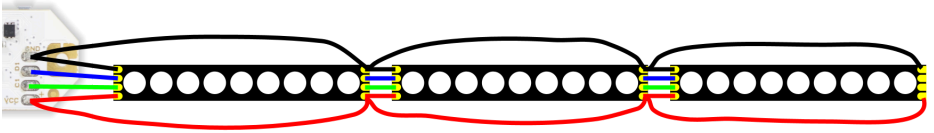

If your project doesn't allow power strengthening at several spots like shown above, try to lead parallel power cables at least to the opposite end of the LED strip:

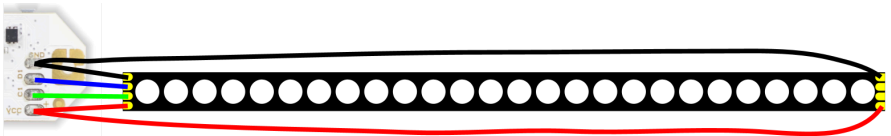

## Radio signal quality

In order to enjoy trouble-free, long range radio communication with the FT remote, make sure that the FT2 chip is not enclosed in a metal enclosure and no metal objects are in close proximity to the antenna area, as shown below:

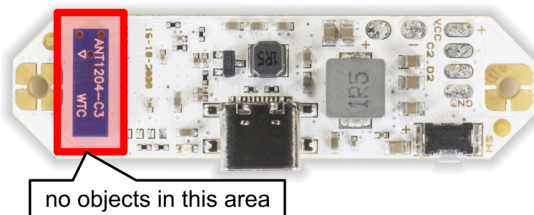

It is advised that the antenna area is kept at least 5 millimeters from any plastic enclosure, LED strip, cables, etc.

## ***B) Bypassing the voltage converter (advanced use case)***

For larger LED projects you may find the power of the built-in voltage converter (40W max) insufficient. In such case, you can completely omit the DC-DC boost circuit by desoldering 2 components (using a heat gun set at  $\sim 300^{\circ}\text{C}$ ) and bridging two capacitor pads with a solder blob joint:

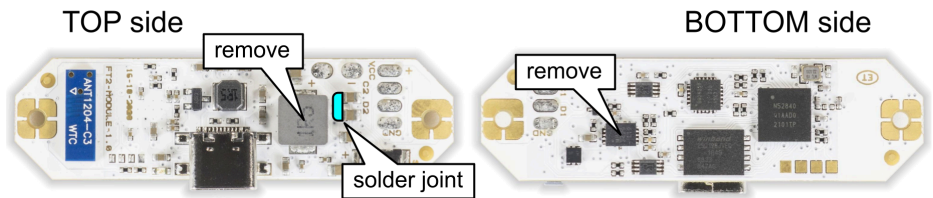

Be advised, that without the DC-DC boost converter the quality and stability of the power supply voltage is now completely up to you.

Please keep in mind that this setup is still limited by the output MOSFET transistor, whose absolute maximum drain current is  $\sim 20\text{A}$ .

## ***C) Using an external 5V power supply***

For static installations which run continuously or with large power consumption, you may want to use a 5 Volt DC power supply instead of Li-ion batteries. In that case the power supply sources power to both the FT2 chip and the digital LED strip.

**Caution: when using the external DC power supply, leave the VCC output pins on the FT2 chip unconnected to prevent damage to the FT2 chip.**

A proper wiring scheme using an external 5V DC power supply and 4 wire digital LED strip is shown below:

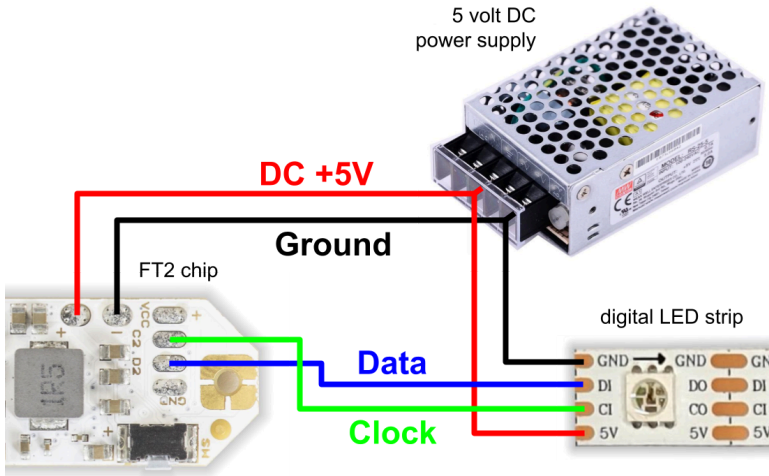

Note: In this configuration the voltage converter is not used, so it doesn't matter if it is bypassed or not.

## ***D) Using WS2815 LED strip with external 12V power supply***

For static installations you can also use the WS2815 LED strip, which uses a 12V source on the LED power lines. This improves efficiency and there is less voltage drop with longer strip lengths.

But keep in mind that the FT2 chip still must be powered with 3.3-5.0V source, like 3.7V Li-ion battery or 5V external power supply. So you have to provide 2 different power sources, which makes the setup more complicated.

An example wiring scheme of WS2815 LED strip using 2 external DC power supplies is shown below:

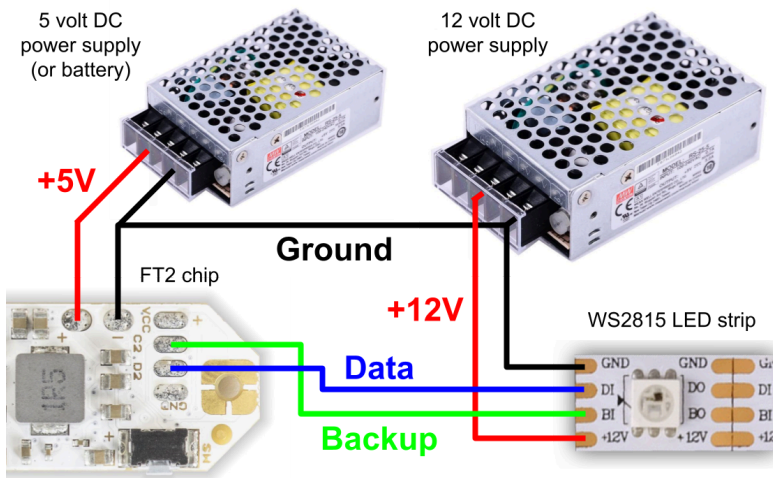

Note: instead of using second 5V DC power supply, you can use a simple linear regulator like LM7805 to convert the 12V voltage to 5V voltage for FT2 chip (power draw ~30mA):

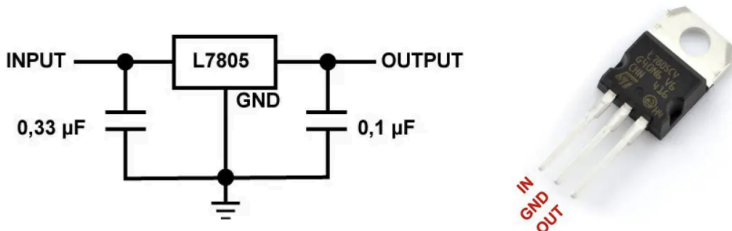

## Warranty & Disclaimer

The FT2 chip is a highly reliable, yet consumable product, so Pyrotterra Lighttoys doesn't offer standard warranty for it. Pyrotterra Lighttoys guarantees that the FT2 chip was rigorously tested and functional when shipped to the customer.

Please understand that the installation of the FT2 chip is at your own risk. You agree that Pyrotterra Lighttoys do not take any responsibility or liability for the possible damage caused by (mis)use of this product in your specific application.



*Team Pyroterra Lighttoys  
wishes you many great moments  
with the FT2 technology!*

